

Printed-Circuit Board for the FT-817 Panadapter

Paul Wade W1GHZ ©2011
w1ghz@arri.net

At Microwave Update 2011, Mike Seguin, N1JEZ, presented “A Panadapter for the FT-817.” I had seen it in action during the 2011 *10 Ghz and Up Contest* and wanted to add one to my FT-817. Mike’s implementation had a couple of breadboards attached with hot-melt glue – real ham construction – with an external coaxial filter. I wanted to integrate it into a printed circuit with a less expensive PC-mounted filter. All credit for this should go to Mike and Don, W1FKF, who worked together on the development – I just made it pretty and more reproducible.

The circuit is unchanged from Mike’s implementation, with everything integrated on the PC board. Here is the schematic:

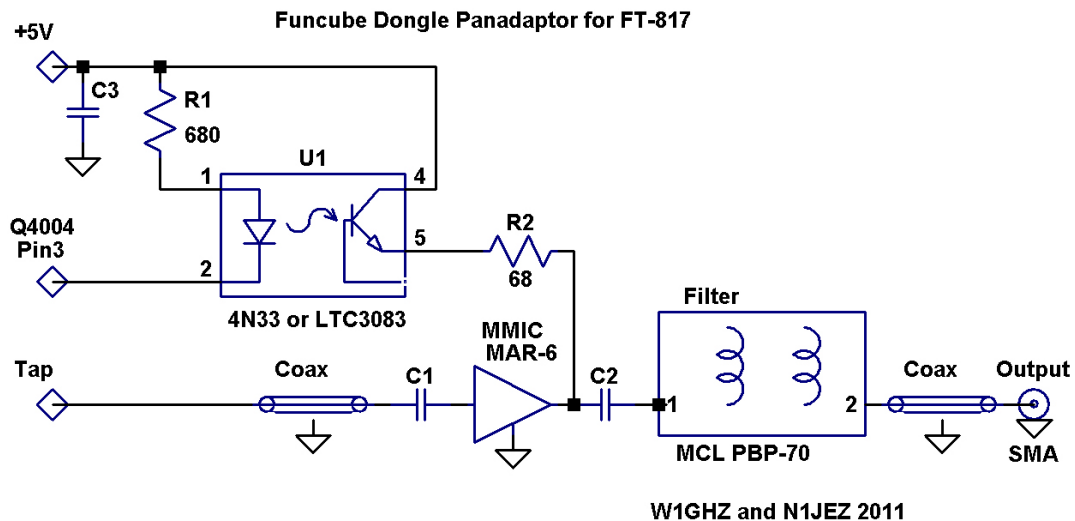

Figure 1 – Schematic of Funcube Dongle Panadapter board

The board is small and narrow, to fit into the limited space available in the FT-817. The top view shows the parts placement and external connections:

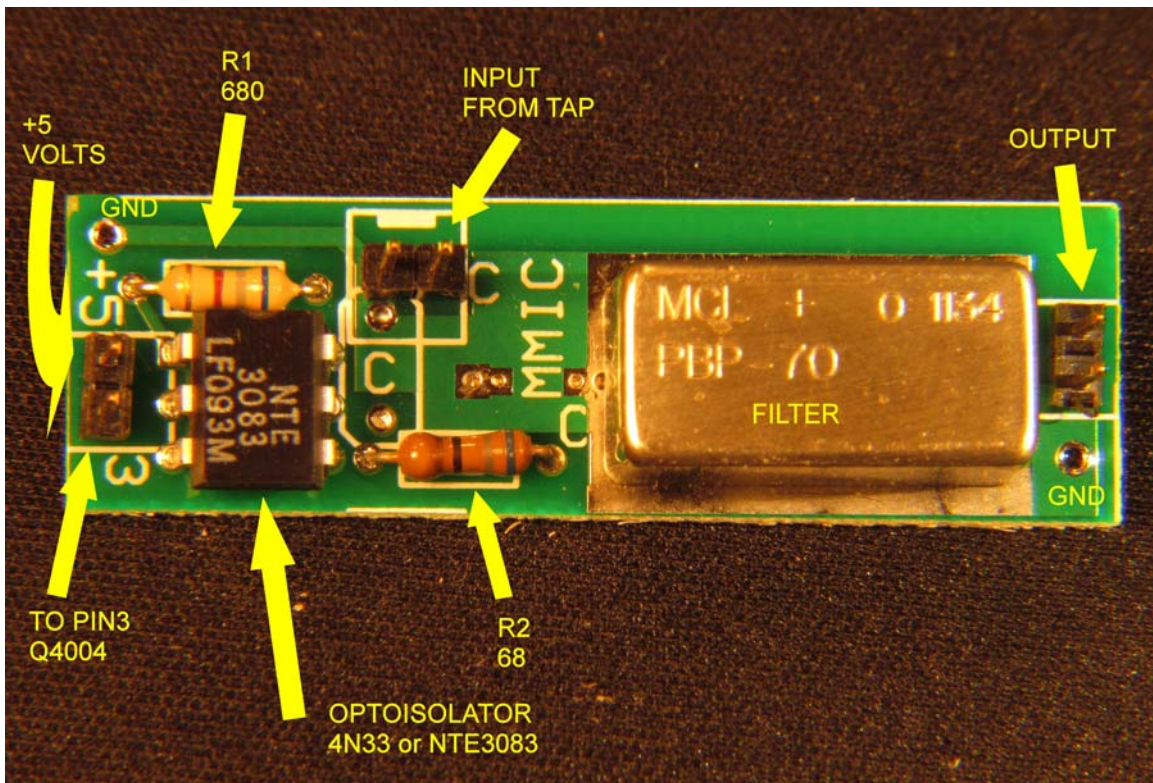

Figure 2 – Top of Panadapter board

The bottom view shows where the MAR-6 MMIC and chip capacitors fit:

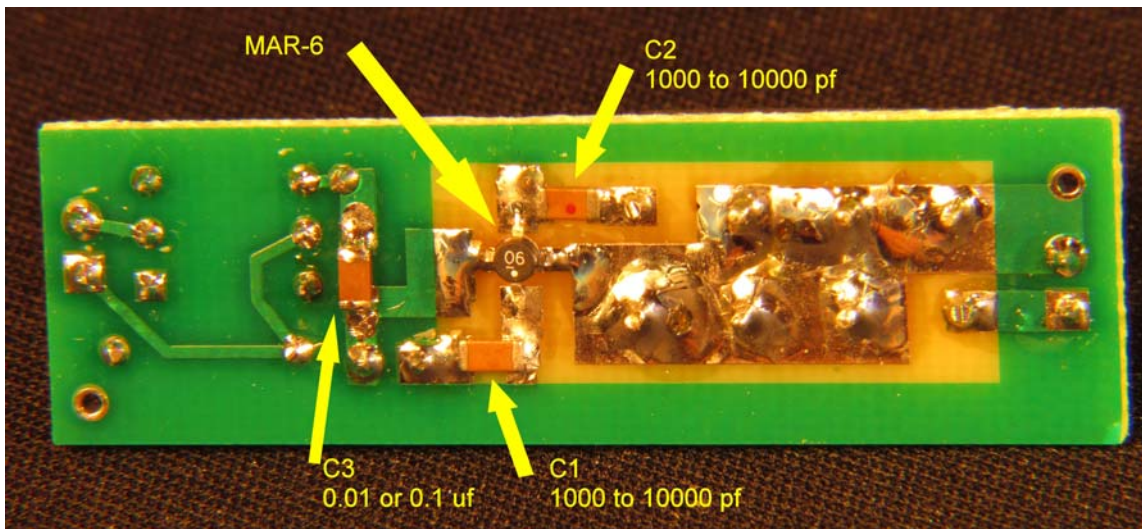

Figure 3 – Bottom view of Panadapter board

Integration

Putting the board together should be pretty straightforward, but integrating it into the FT-817 is a bit more work. Start by taking the covers off the FT-817, then comparing with the pictures below to get oriented. Figure 4 shows the completed installation, with the board tucked in behind the front panel, using the space intended for the optional filter. The output coax goes to an SMA connector on the back panel – I used a cordless drill to gently drill through the back panel. Don't forget to put a piece of tape on the inside of the panel before drilling to catch the chips before they get inside the radio.

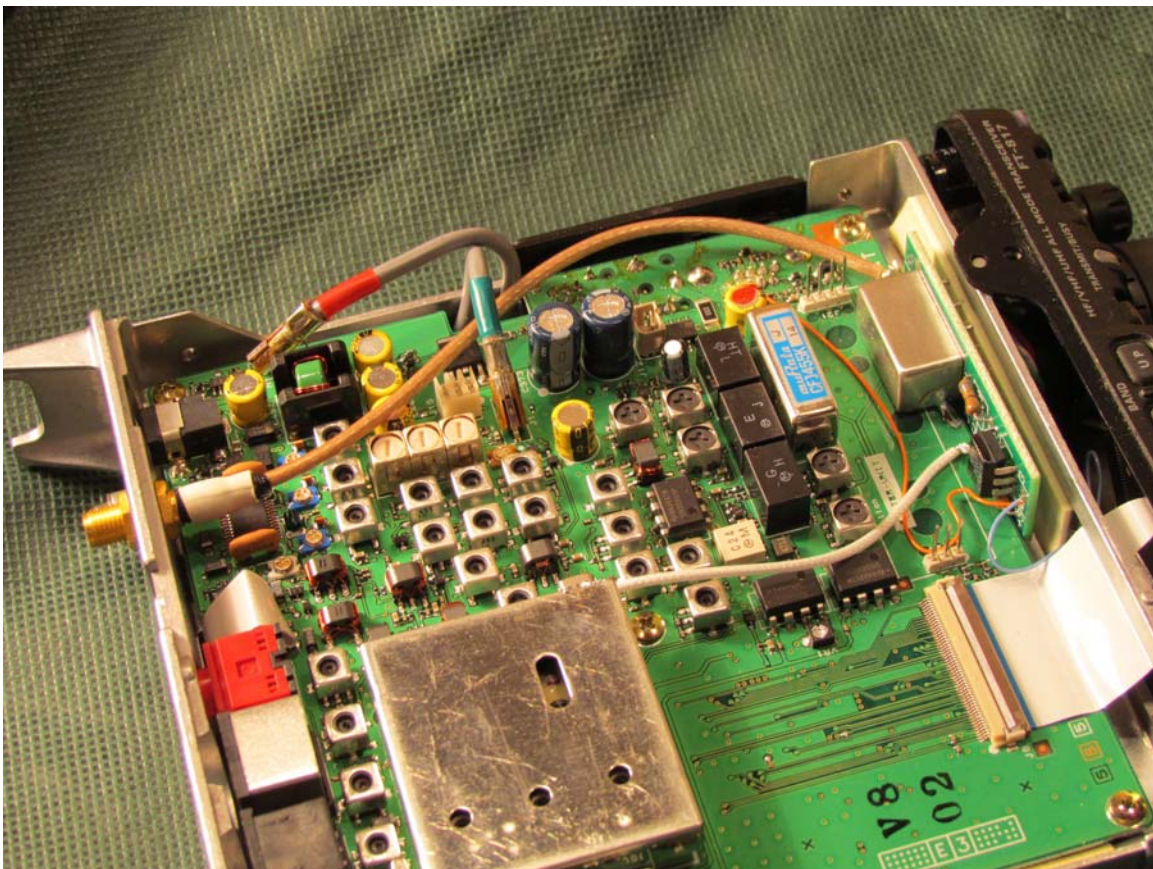

Figure 4 – Panadapter board installed in FT-817

Figure 5 is a closeup of the board installation. I put some double-sided foam tape between the bottom of the board and the metal wall of the radio. The filter is soldered down to the FT-817 main board at both ends – I scraped off the green solder mask to make the connection.

The orange wire goes to pin 6 of the RJ-45 mike connector to provide +5 Volts, and the blue wire goes to the Front Panel board of the FT-817, connecting to pin 3 of IC Q4004, as shown in Mike's paper. I used wire-wrap wire, #30 AWG, which just fits in the tiny hole in the Front Panel board.

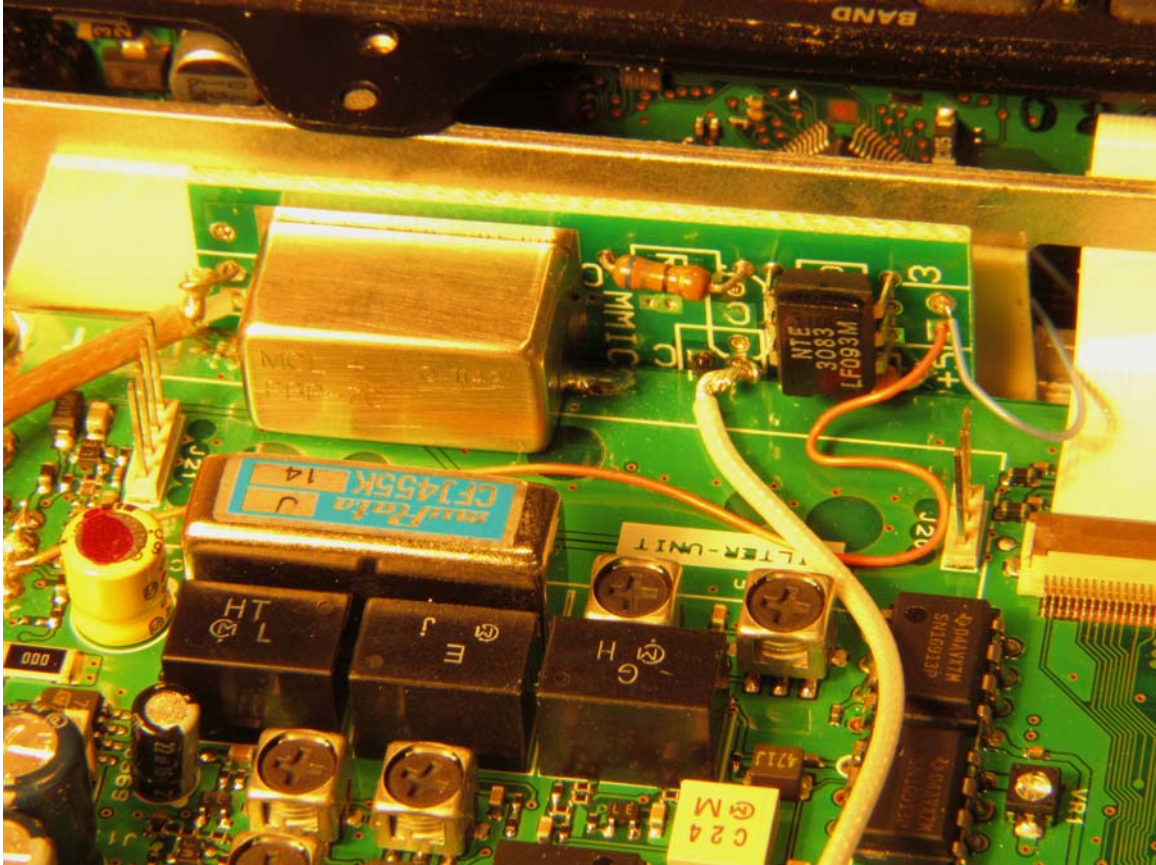

Figure 5 – Panadapter board installed in FT-817 (no CW filter)

While you have the Front Panel board accessible, it only takes a minute to open up the FT-817 to transmit over the full range. See instructions by LA8OKA at www.mods.dk. Of course, we would only use this for transverter operation.

Figure 6 shows the IF tap point before the filter. The shield of the coax connects to the adjacent shield can, and the center conductor to the filter. Mike soldered directly to the filter pin, but I found that the center conductor of the small coax would fit into the tiny hole in the PC board connecting to the filter, as shown in the photo.

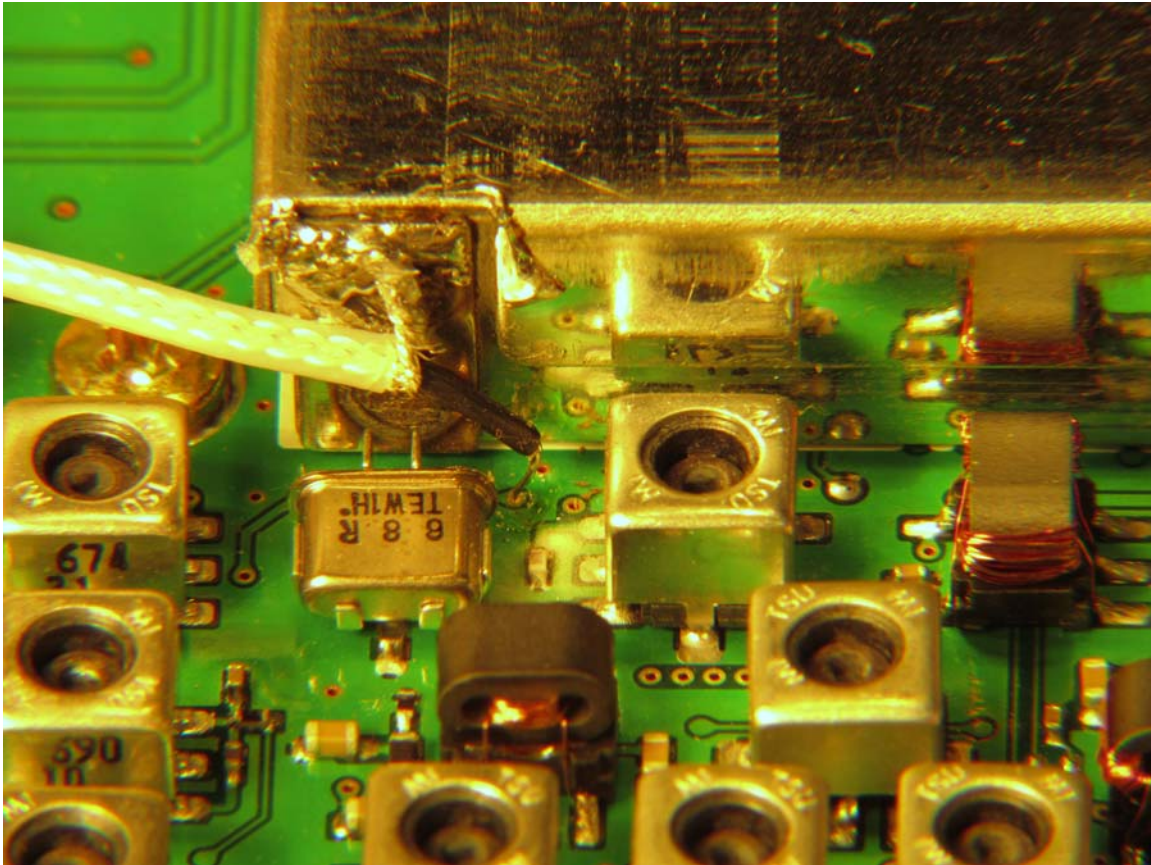

Figure 6 – Signal tap at FT-817 filter input

Note that Figure 6 shows the coax connected directly to the filter, while Mike had a 5 pf capacitor between the coax and filter to reduce loading on the circuit. I tried it both ways and found that the direct connection makes the panadaptor more sensitive by several dB, so that you can see signals that you can't hear. The FT-817 gain is reduced slightly, but weak signal sensitivity is not affected. W1FKF and N1JEZ have both done the comparison with similar results.

That should do it. Before replacing the covers, fire it up. Connect the Funcube Dongle, tune it to 68.33 MHz, and tune in a signal on the FT-817. If all is working, the signal should show up in the middle of the panadaptor display. (This assumes you have the software working and configured

already.) I had a bit of trouble because I mistakenly tuned the Funcube Dongle to 69.33 MHz the first time and didn't see any signals.

An FT-817 with the optional CW filter is more of a challenge. Figure 7 shows how Mike squeezed one in.

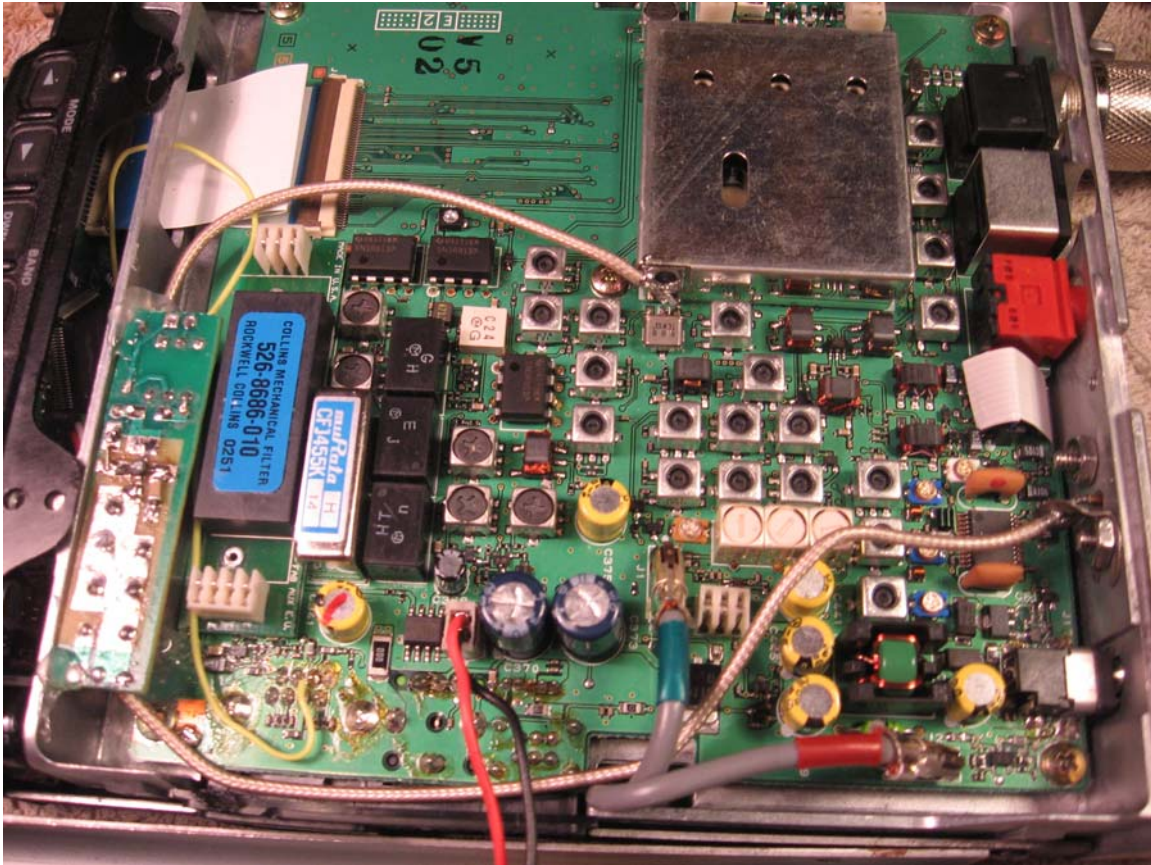

Figure 7 – N1JEZ installation with CW filter in FT-817

PTT for Transverter

While I had the FT-817 open, I took the opportunity to add transverter PTT to the radio, so that it puts voltage on the rear coax connector when transmitting. This eliminates the need to run a separate PTT line to the transverter, so only a run of coax is needed for remote operation – a real benefit when operating on hilltops in bad weather. This is a pretty simple modification by ON7WP from www.mods.dk. My version is shown in Figure 8.

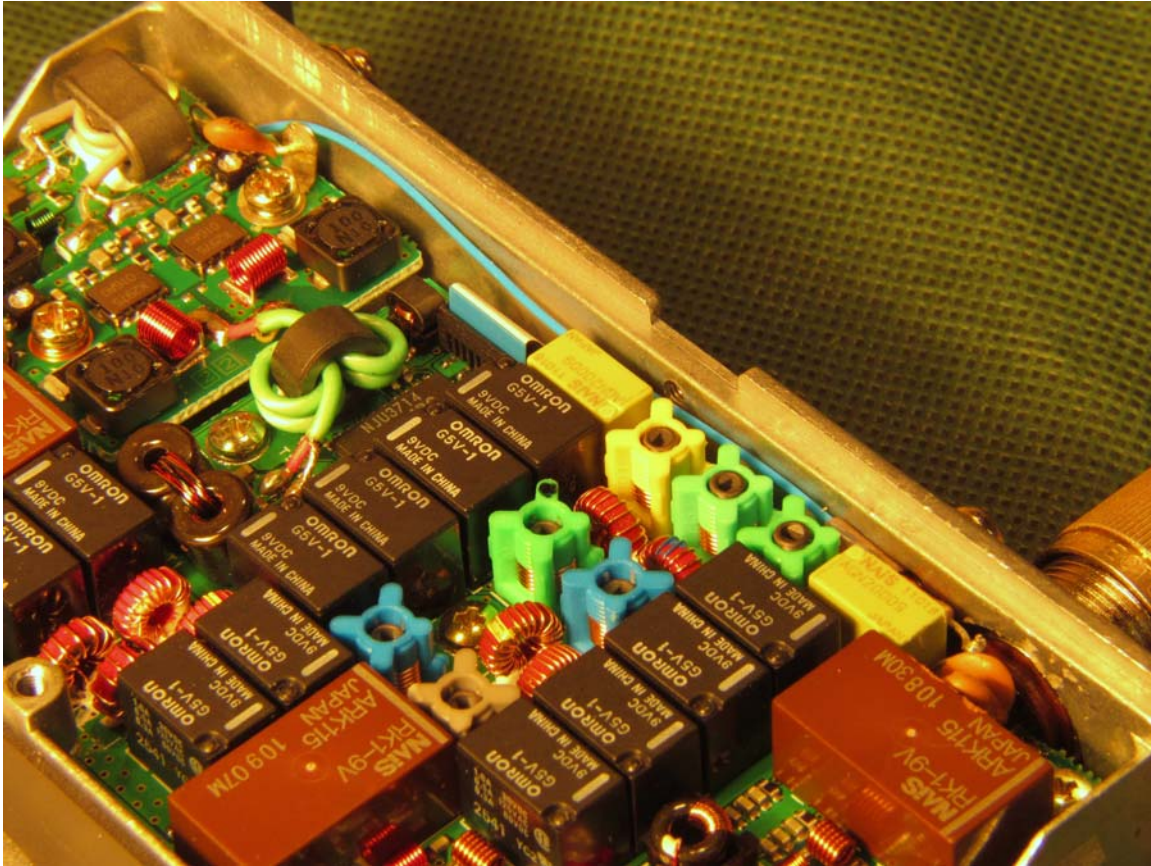

Figure 8 – PTT voltage on rear output connector

Summary

The Funcube Dongle is a good way to add a panadapter to the FT-817, a real aid to microwave operation, where finding weak signals can be a challenge. The modification is simple and does not affect normal operation when the panadapter is not needed. The PC boards are available at www.w1ghz.org.

There is no reason the Funcube Dongle and this PC board couldn't be used with other radios. Please write up your results after you figure it out.